

NRR DIESEL

CREW CAB

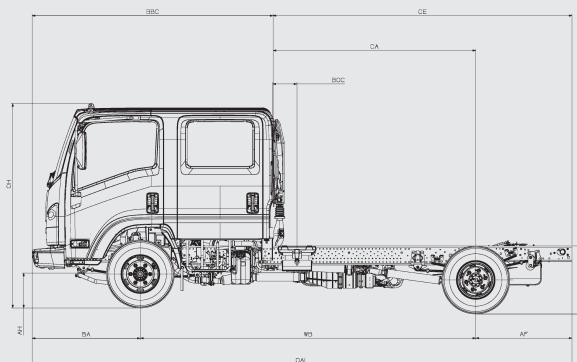

GVWR/GCWR	19,500/25,500 lbs.
BODY/PAYLOAD ALLOWANCE	12,181-12,250 lbs.
GAWR	
Front	7,275 lbs.
Rear	13,660 lbs.
FRONT AXLE CAPACITY	7,275 lbs.
REAR AXLE CAPACITY	14,550 lbs.
Ratio	5.571
SUSPENSION F/R SPRINGS	Tapered/Multi-Leaf
Capacity	8,440/14,550 lbs.
FRAME	
Section Modulus	11.89 in. ³
Resistance Bending Moment	523,160 lb.-in.
SERVICE BRAKES	Hydraulic Boosted with 4-Channel ABS Disc/Drum
Front/Rear	
EXHAUST BRAKE	Standard
TRANSMISSION	Aisin A465id 6-speed auto. with double overdrive and lock-up 2 nd -6 th gears
ENGINE	Isuzu 4HK1-TC turbocharged intercooled diesel
Displacement	5.2L (317 in. ³)
Engine Power	215 hp @ 2,500 rpm
Engine Torque	452 lb.-ft. @ 1,850 rpm
OIL LEVEL INDICATOR	Dash-mounted oil level check switch and light
LIMITED SLIP DIFFERENTIAL	Optional
ALTERNATOR	140-amp
BATTERIES	2 Maintenance-Free 750-CCA
TIRES LRR (Low Rolling Resistance)	225/70R19.5F (12-pr) Standard
STEERING	Integral Hydraulic Power
STEERING COLUMN	Tilt and Telescopic
FUEL TANK	
Standard	30 gal. in-rail
FUEL/WATER SEPARATOR	Dual fuel filter with dash mounted indicator light

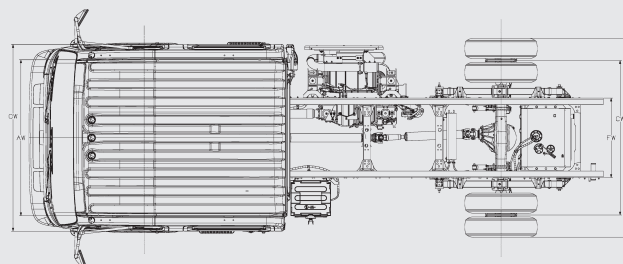

NRR DIESEL CREW CAB									
Wheelbase (in.)	Cab to Axle (in.)	Cab to End of Frame (in.)	Back of Cab (in.)	Overall Length (in.)	Overall Width (in.)	Axle Width (in.)	Overall Height (in.)	Body Length (ft.)	
150.0	88.5	131.6	5.3	241.5	81.3	65.6	92.4	12	
176.0	114.5	157.6	5.3	267.5	81.3	65.6	92.4	16	