



NPR-HD GAS

CREW CAB



GVWR/GCWR	14,500/20,500 lbs.
BODY/PAYLOAD ALLOWANCE	8,442 - 8,503 lbs.
GAWR	
Front	6,630 lbs.
Rear	11,020 lbs.
FRONT AXLE CAPACITY	6,830 lbs.
REAR AXLE CAPACITY	11,020 lbs.
Ratio	4.300
SUSPENSION F/R SPRINGS	Tapered/Multi-Leaf
Capacity	8,440/12,900 lbs.
FRAME	
Section Modulus	7.20 in. ³
Resistance Bending Moment	316,800 lb.-in.
SERVICE BRAKES	Vacuum/Hydraulic with 4-Channel ABS Disc/Drum
Front/Rear	
TRANSMISSION	6L90 6-speed auto. with double overdrive and lock-up converter
ENGINE	GMPT L96 (Gen IV) V8 Vortec 6000 (Optional: K18 - Alternative Fuel Capable Engine)
Displacement	6.0L (365 in. ³)
Engine Power	297 hp @ 4,300 rpm
Engine Torque	372 lb.-ft. @ 4,000 rpm
LIMITED SLIP DIFFERENTIAL	Optional
ALTERNATOR	145-amp
BATTERIES	1 Maintenance-Free 750-CCA
TIRES LRR (Low Rolling Resistance)	225/70R19.5F/G (12/14-pr) Standard
STEERING	Integral Hydraulic Power
STEERING COLUMN	Tilt and Telescopic
FUEL TANK	30 gal. in-frame

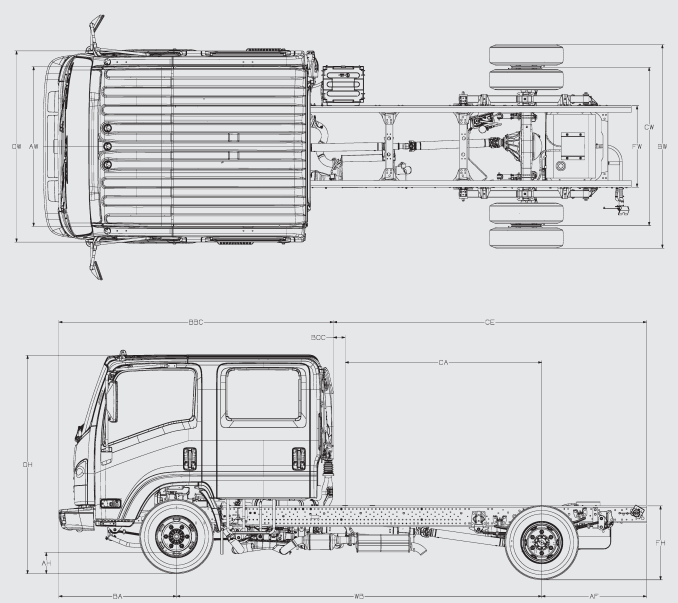

NPR-HD GAS CREW CAB								
Wheelbase (in.)	Cab to Axle (in.)	Cab to End of Frame (in.)	Back of Cab (in.)	Overall Length (in.)	Overall Width (in.)	Axle Width (in.)	Overall Height (in.)	Body Length (ft.)
150.0	88.5	131.6	5.0	241.5	81.3	65.6	91.1	12
176.0	114.5	157.6	5.0	267.5	81.3	65.6	91.1	16